



**Andrea Falcone**

University of Pavia  
INFN Pavia

Comparison  
between large area  
PMTs at cryogenic  
temperature for  
neutrino and rare  
event physics  
experiments

# Rare event physics experiment

---

- ✓ Various detectors dedicated to rare events physics (**neutrino physics** and **Dark Matter search**) use liquid noble gases (Argon, Xenon) as active medium.
- ✓ Liquid noble gases act as **scintillators**: light is produced by excitation and recombination phenomena occurring after the passage of ionizing particles.
- ✓ Light collection is mandatory in this kind of detectors. It has been used both for **identification** of interacting particle (WArP, Xenon) and for **triggering** events (ICARUS).

# Large area PMT at cryogenic temperature

---

- ✓ Various technological problems arise while working with liquid noble gases: work at **cryogenic temperature** (77 K and 165 K for Ar and Xe respectively) and **VUV light emission** (128 nm and 165 nm for Ar and Xe respectively).
- ✓ **Cryogenic temperature**: special PMTs with bialkali ( $K_2CsSb$ ) deposited on Pt under-layers for photocathode and diodes, in order to extend the range of temperatures the devices can be operated at.
- ✓ **VUV or UV light emission**: PMTs are not usually sensitive to VUV emission, therefore windows need to be coated with wavelength shifters, an example being TetraPhenyl-Butadiene (TPB).

- ✓ We tested new generation 8-inch PMTs in view of their use in future large mass detectors : Hamamatsu R5912 Mod and R5912-02 Mod and ET 9354 KB.
- ✓ Main characteristics of the devices at 77 K are reported below.
- ✓ Some problematic behaviour occurred while testing ET 9354 KB. We decided not to make tests on it at cryogenic temperature, before clarifications with the manufacturer. As no SER was detectable in this PMT, measurements are made with multi electron response.

	<b>R5912</b>	<b>R5912-02</b>	<b>ET 9354 KB</b>
Dynodes	10	14	12
Alimentation	Anode at ground	Anode at ground	First dynode at ground
S.E.R. peak to valley	2.8	2,6	1
Rise Time	3.8 ns	3.6 ± 0.9 ns	
FWHM	4.4 ± 0.1 ns	5.0 ± 0.8 ns	

- ✓ We adopt as reference the characteristics of ETL 9357 FLA PMTs, used in the ICARUS experiment.
- ✓ These PMTs worked very well for timing and trigger purposes of the experiment.

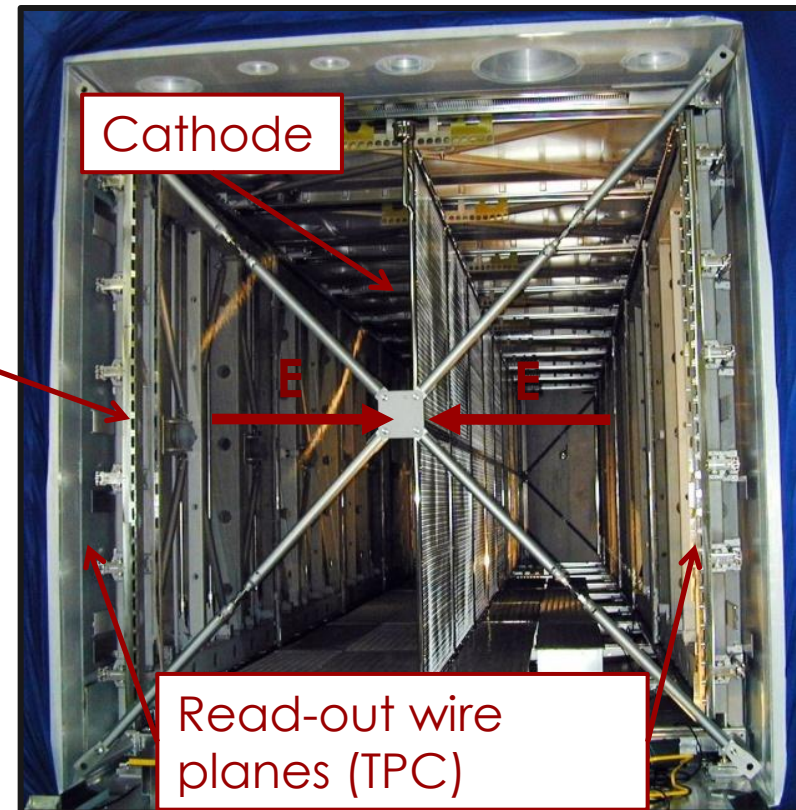

	Provided	Measured at 77 K
Window diameter	8 in (20 cm)	
Dynodes	12	
Dynodes Material	K <sub>2</sub> CsSb on Pt layer	
Alimentation	First dynode at ground	
Q.E. at 400 nm	20%	
S.E.R. peak to valley	2.3	1.8
Rise Time	5 ns	3.9 ± 1.1 ns
FWHM	8 ns	7.3 ± 1.4 ns

## References

- *Characterization of ETL 9357FLA photomultiplier tubes for cryogenic temperature applications – NIM A 556 (2006) 146 -157*
- *The trigger system of the ICARUS experiment for the CNGS beam - arXiv:1405.7591 [physics.ins-det]*



- Characterization at room temperature
  - ✓ Cathode uniformity
  - ✓ Behaviour with the terrestrial magnetic field
    - Gain
    - Electron transit time
  - ✓ Quantum efficiency with TPB coating
  
- Characterization at cryogenic temperature
  - ✓ Gain
  - ✓ Linearity
  - ✓ Dark counts
  
- Conclusion

# Photocathode uniformity

- ✓ The PMT is enlightened with a 400 nm laser diode, by means of an optical fibre. Data are then analyzed with a Multi Channel Analyzer ( MCA ).
- ✓ A proper support is used, able to sustain the optical fibre, normal to the PMT window surfaces at various position.
- ✓ The SER is studied as a function of the position along two perpendicular orthodromes.

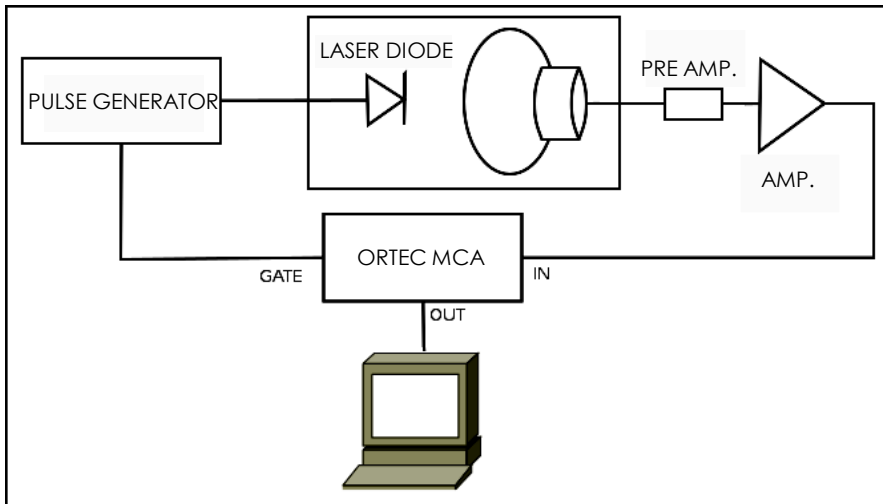



# Photocathode uniformity

✓ Good photocathode uniformity in the central region (till 10 cm from centre) for the R5912.

✓ Worst uniformity and problem in part of the photocathode for the ET 9354 KB.

R5912

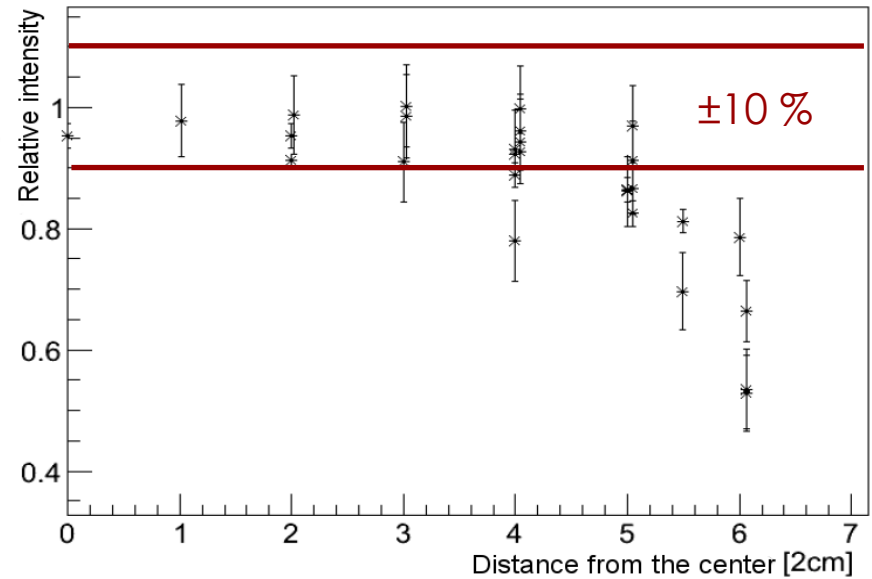

ET 9354 KB

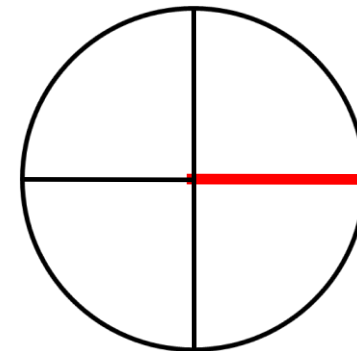
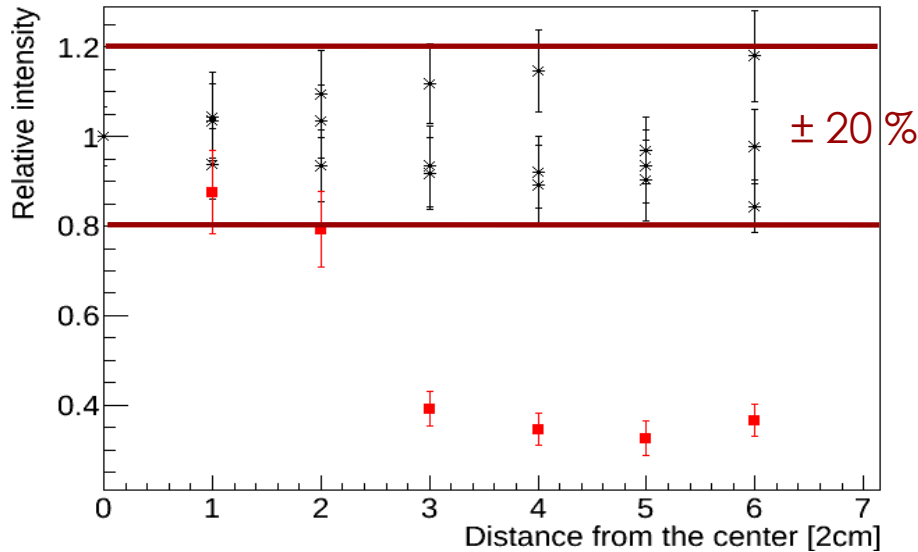

✓ Further measurements were made for ET 9354 KB in the area highlighted previously, and they hint to a probable deformation of the photocathode

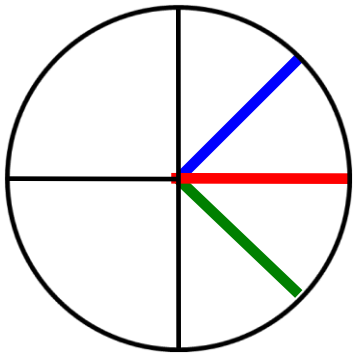

ET 9354 KB

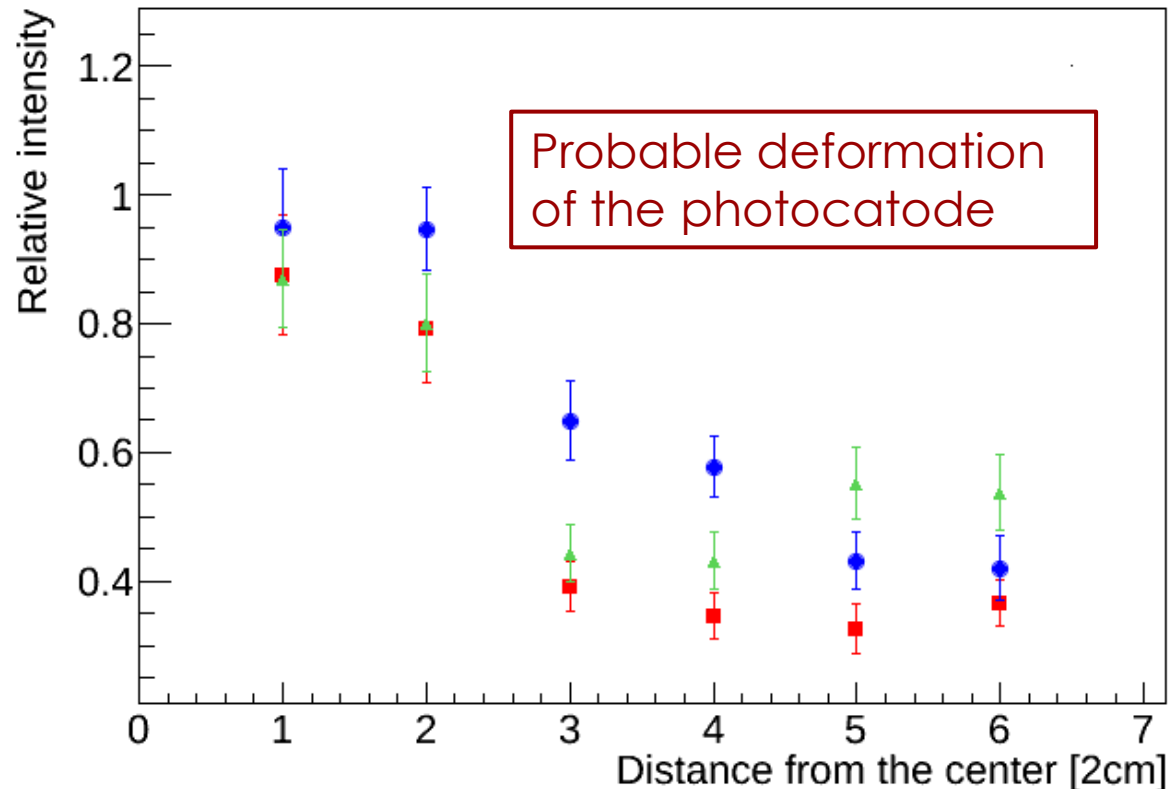

- ✓ The PMT is enlightened with a 400 nm laser diode, by means of an optical fibre fixed at the centre of the PMT window.
- ✓ PMT axis is parallel to the ground.
- ✓ Different measurements are made turning the PMT on its own axis.
- ✓ For gain measurement same configuration as before is used ( pre-amplifier, amplifier and MCA analyzer).
- ✓ To measure the transit time, R5912 and R5912-02 signals are acquired directly with the oscilloscope. For the ET 9354 KB a TAC module and the MCA are used.

# Behaviour in magnetic field – Gain

✓ Measurement at different angles are reported, with unit intensity referred to measurement with  $\mu$ -metal shielding.

✓ A significant dependence on the terrestrial magnetic field is clearly visible.

R5912

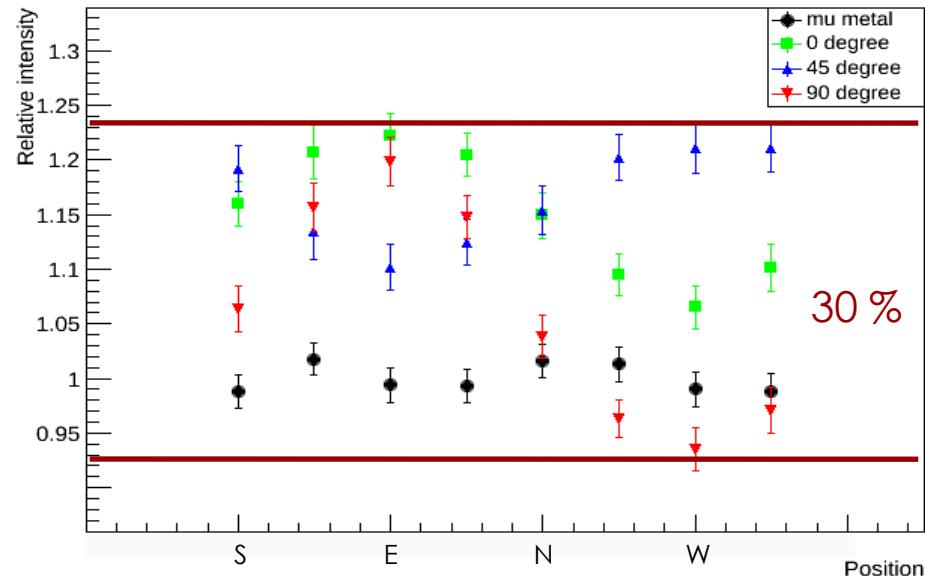

R5912 - 02

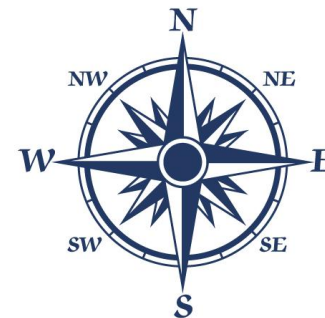
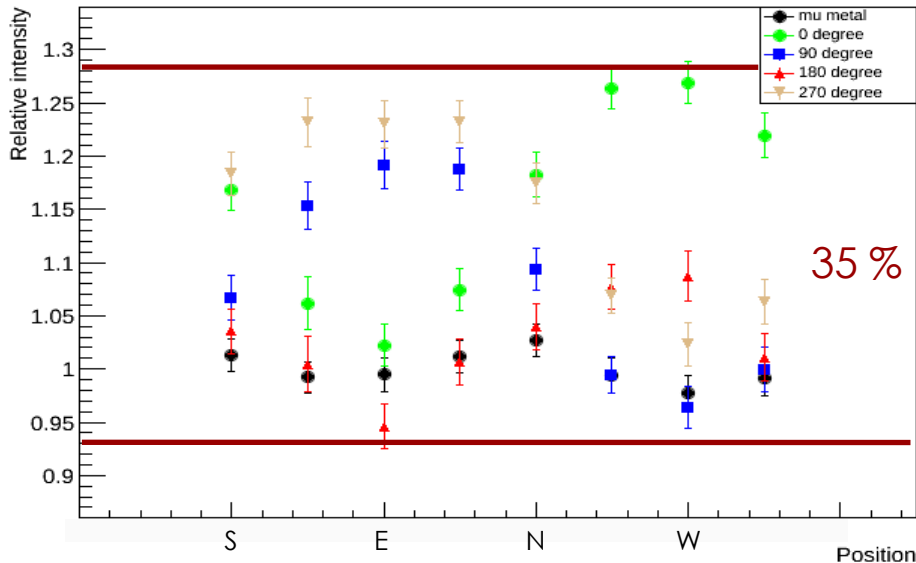

✓ Measurements with fibre fixed at different distance from the centre of PMT indicate that the response is the less affected by magnetic field, the farther from the centre. This can be due to the non uniform electric field configuration inside the PMT.

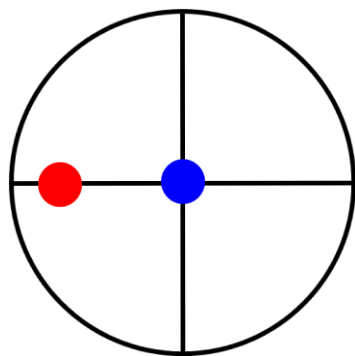
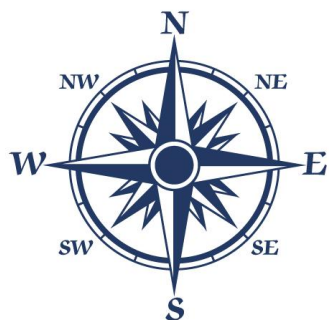

ET 9354KB

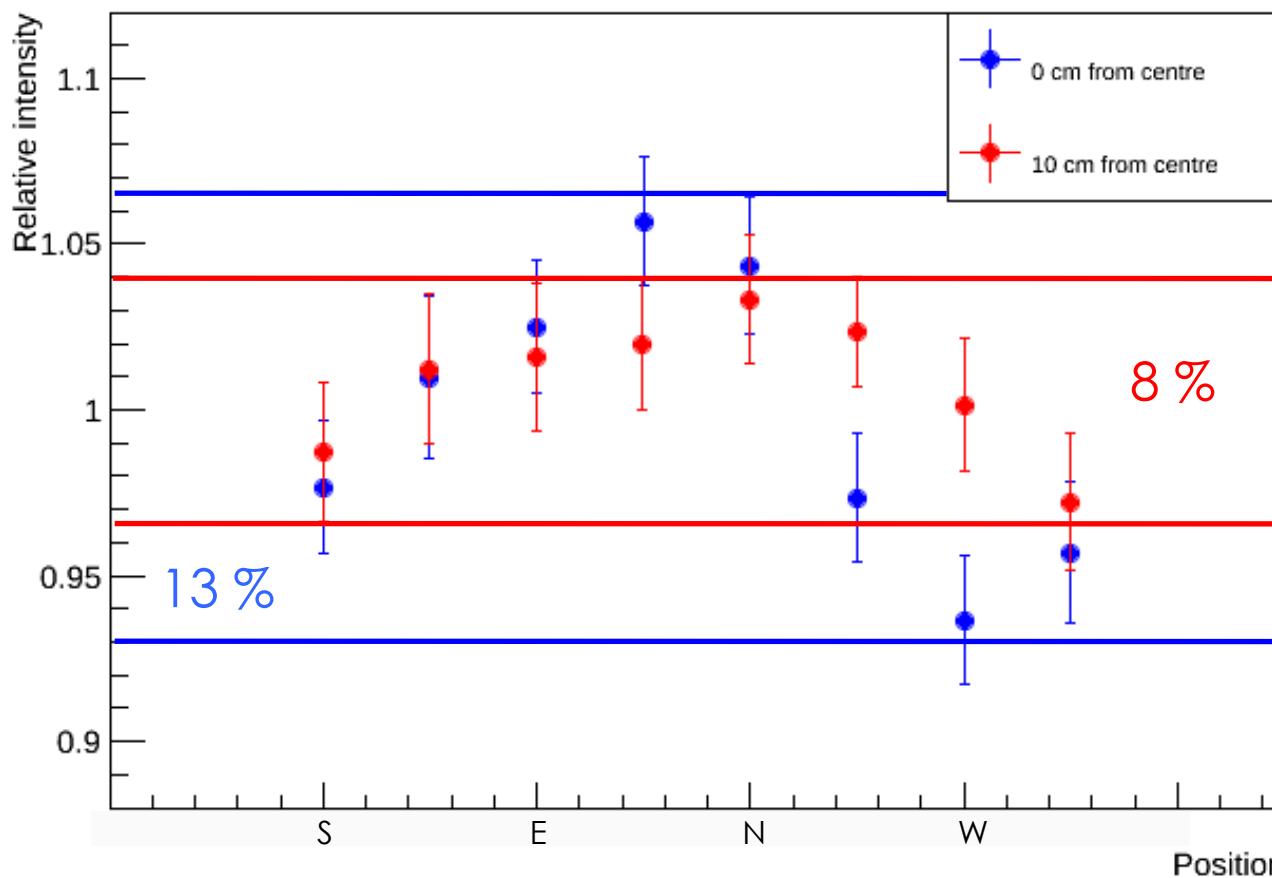

## R5912

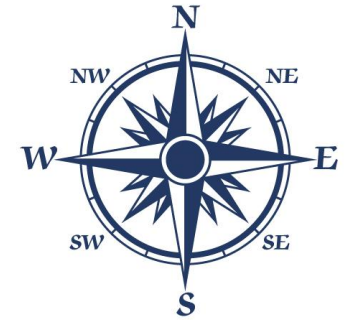
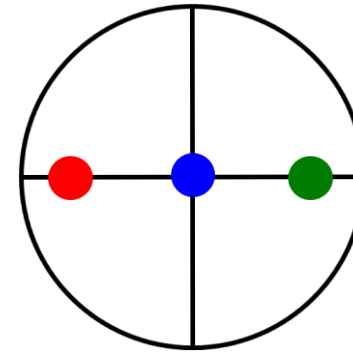
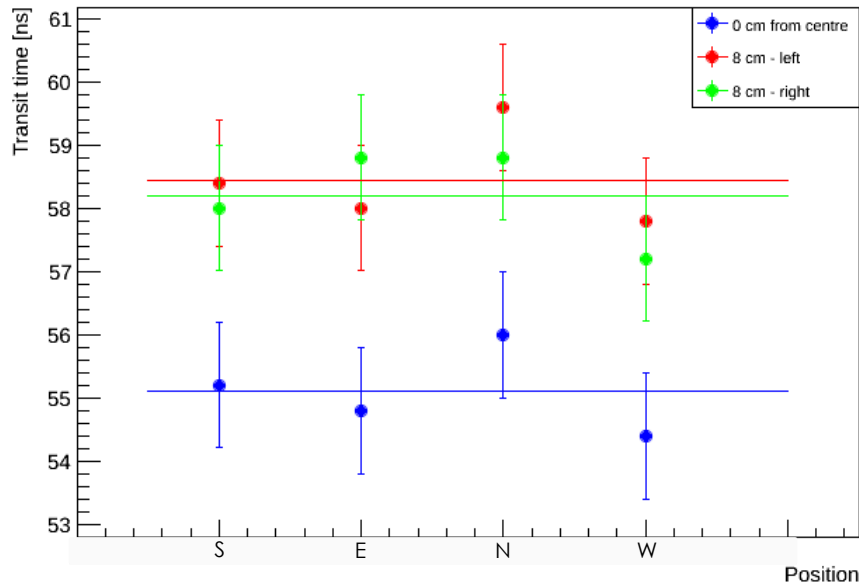

✓ Transit time seems to be not affected by terrestrial magnetic field. It increases with increasing distance from the PMT window centre.

## ET 9354KB

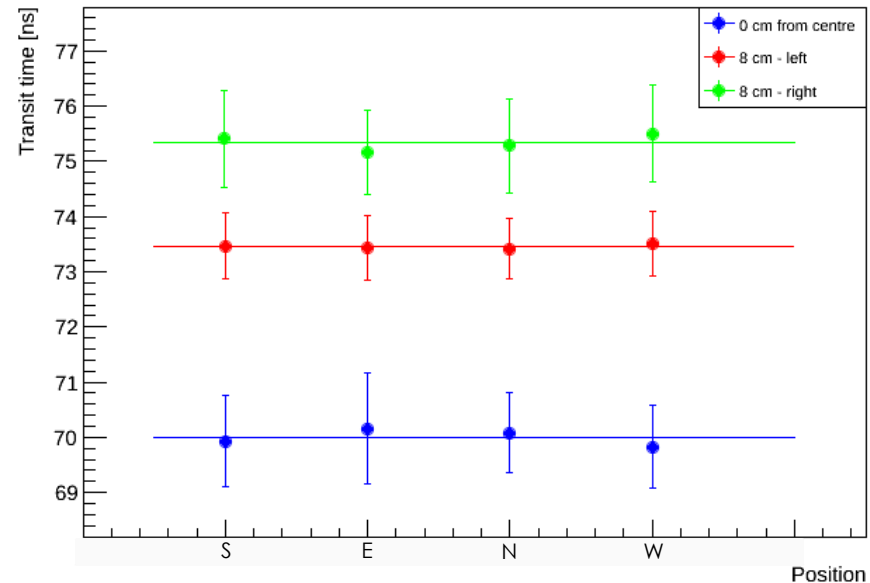

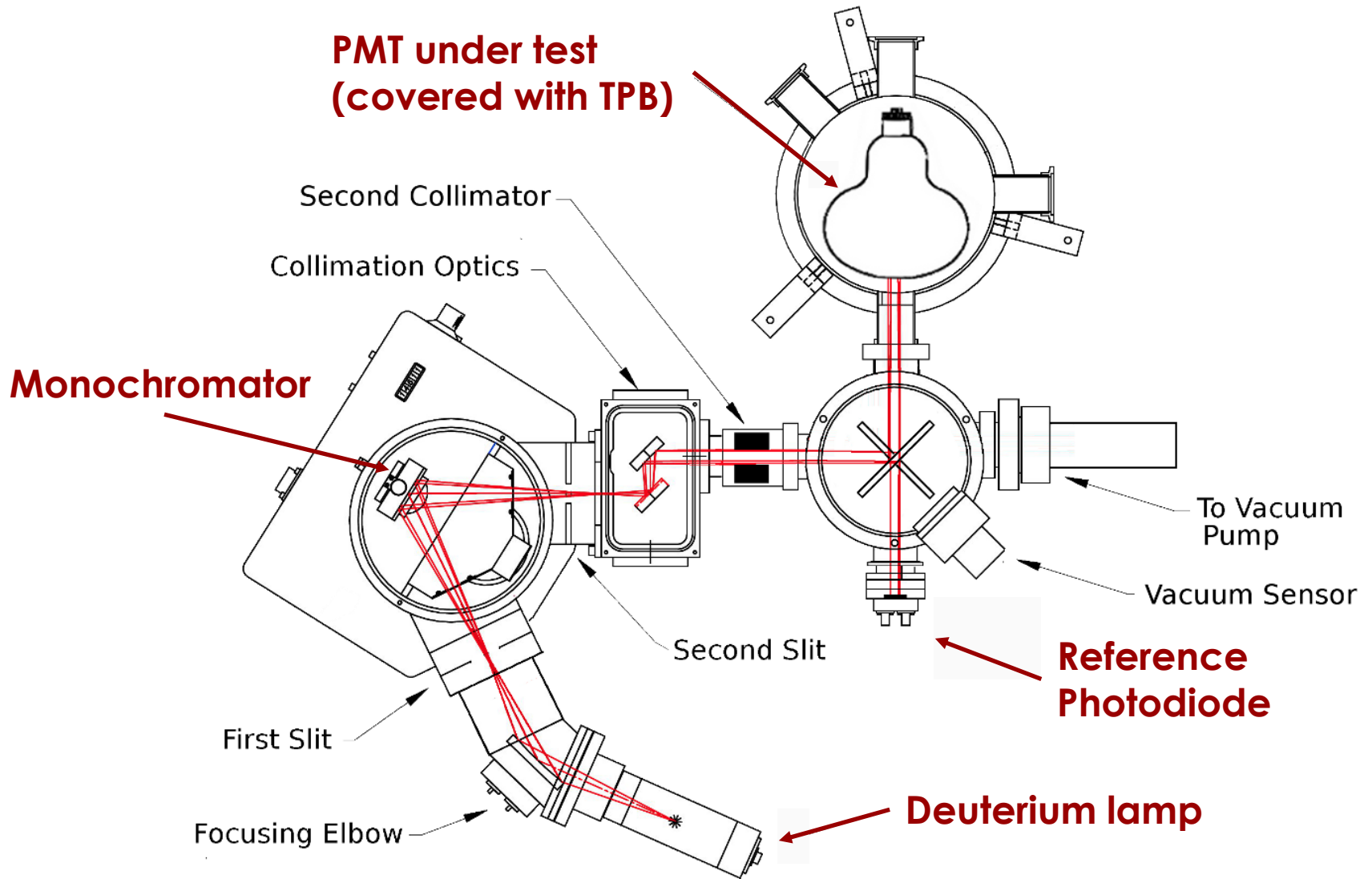

- ✓ Quantum efficiency is measured, as a function of wavelength, by comparing the current produced on the photo-cathode with that collected with a reference diode, enlightened with the same amount of light.
- ✓ All PMTs show a Quantum Efficiency of the order of few percent to VUV incident light, when coated with TPB. Comparison is reported between Q.E. of different PMTs, at the wavelength of liquid Argon and liquid Xenon emission peaks.

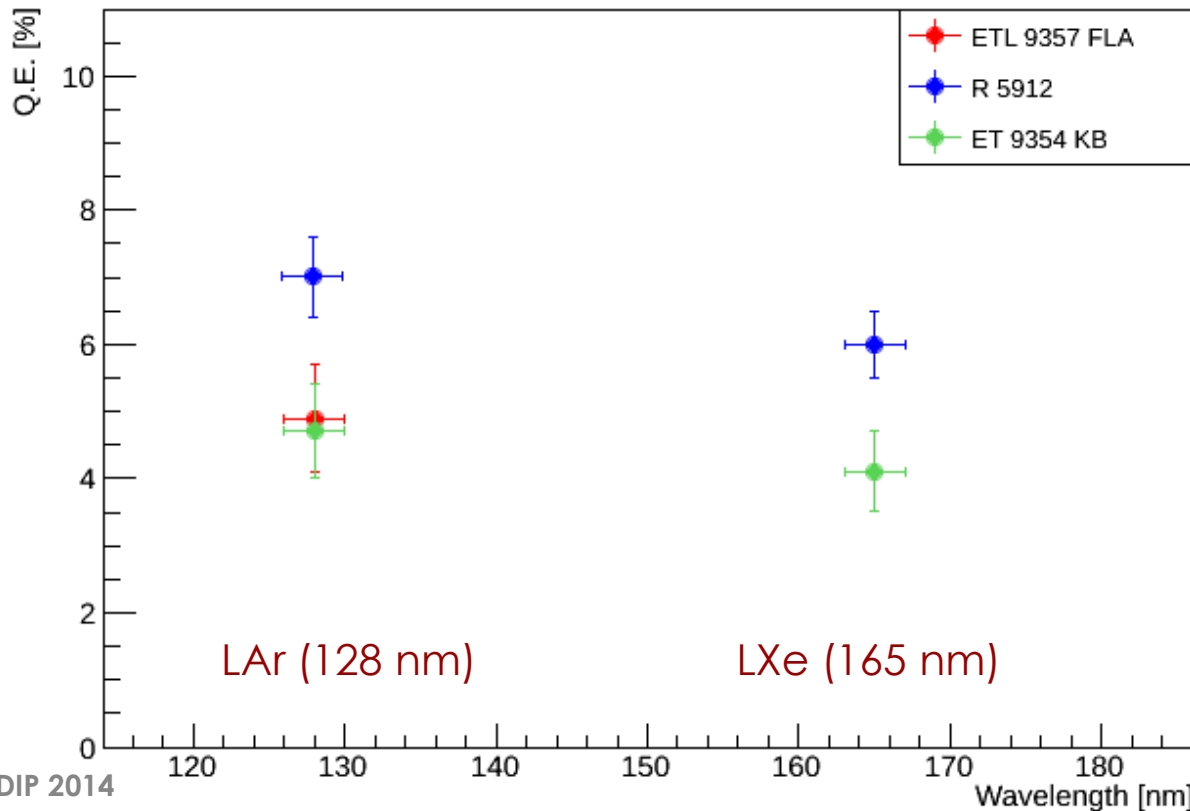



- ✓ PMT are directly immersed in liquid Nitrogen, to test them in real experimental conditions. Measurement are carried out after a couple of days of rest in cryogenic environment.
- ✓ The PMT is enlightened with a 400 nm laser diode, by means of an optical fibre fixed at the centre of the PMT window. The fibre and the other cables are allowed to enter by a proper cap, used to preserve darkness conditions and thermal insulation.
- ✓ For gain measurement same configuration as before is used ( pre-amplifier, amplifier and MCA analyzer).
- ✓ Dark rate is measured with a counter and a discriminator. A complete spectrum can then obtained with a dedicated computer program that gradually increase the discrimination threshold.
- ✓ The data relative to 54 ETL 5397 FLA PMTs mounted on ICARUS T600 detector are shown as a reference.

## ETL 9357 FLA

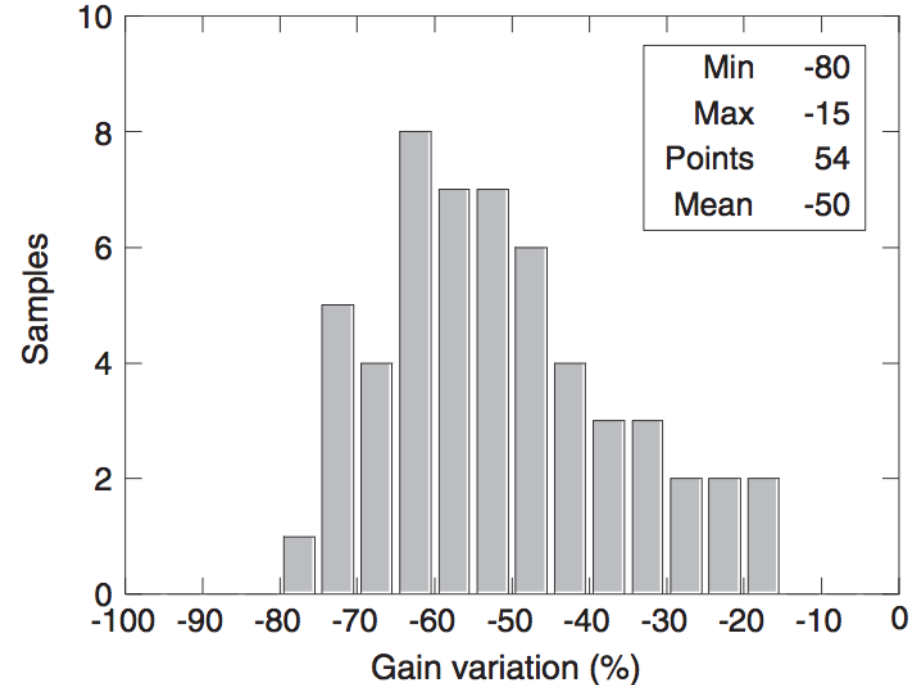
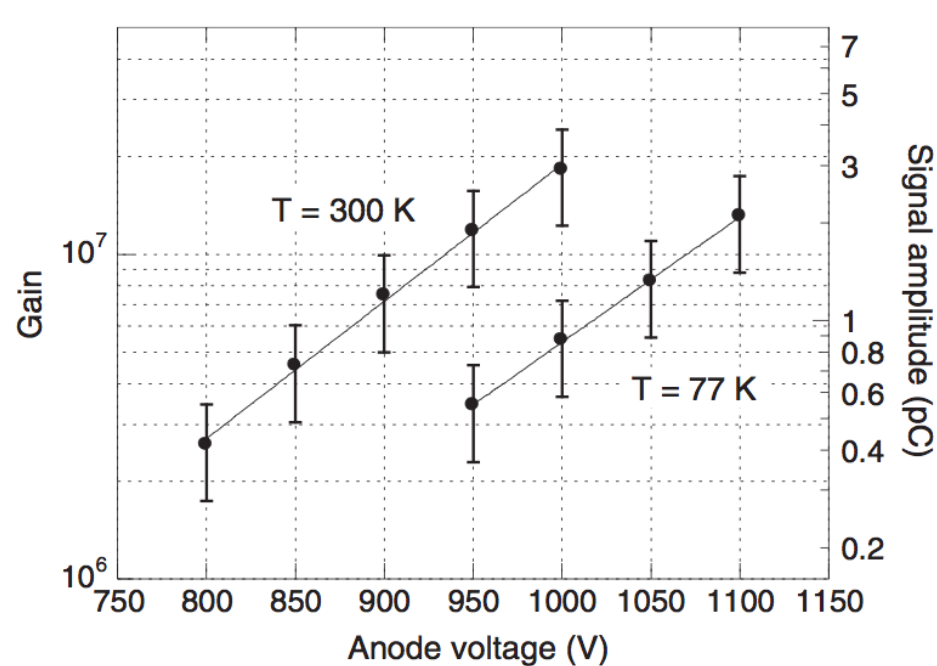

✓ ICARUS PMTs: values fitted by an exponential law  $G = \exp(\alpha V_A)$ , as a function of the anode voltage  $V_A$ .  $\alpha = 0,017$  and  $\alpha = 0,015$  relative to 300 K and 77 K respectively.

✓ Gain **reduction** at 77 K for the entire sample lies **between 15% and 80%**.

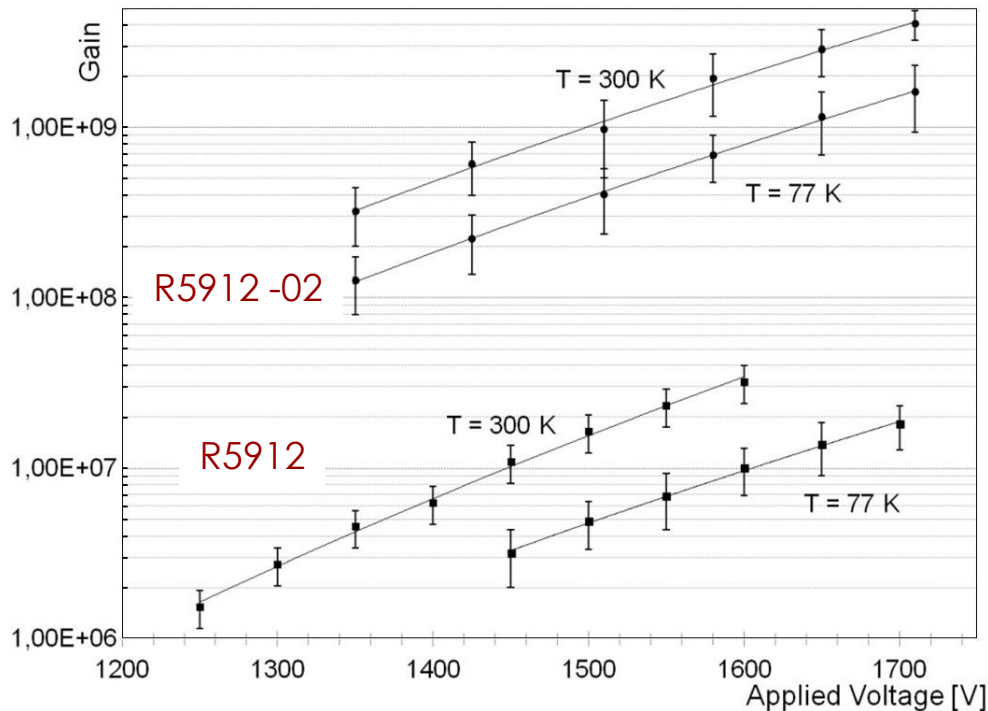

✓ Values well fitted by a power law function  $G=V^{\beta n}$ , as a function of the dynodic voltage  $V$ .  $n$  is the number of dynodes and  $\beta$  ranges **between 0.7 and 0.8**.

✓ Gain **reduction** at 77 K: **35 %** for the R5912 and **34%** for the R5912-02.

## ETL 9357 FLA

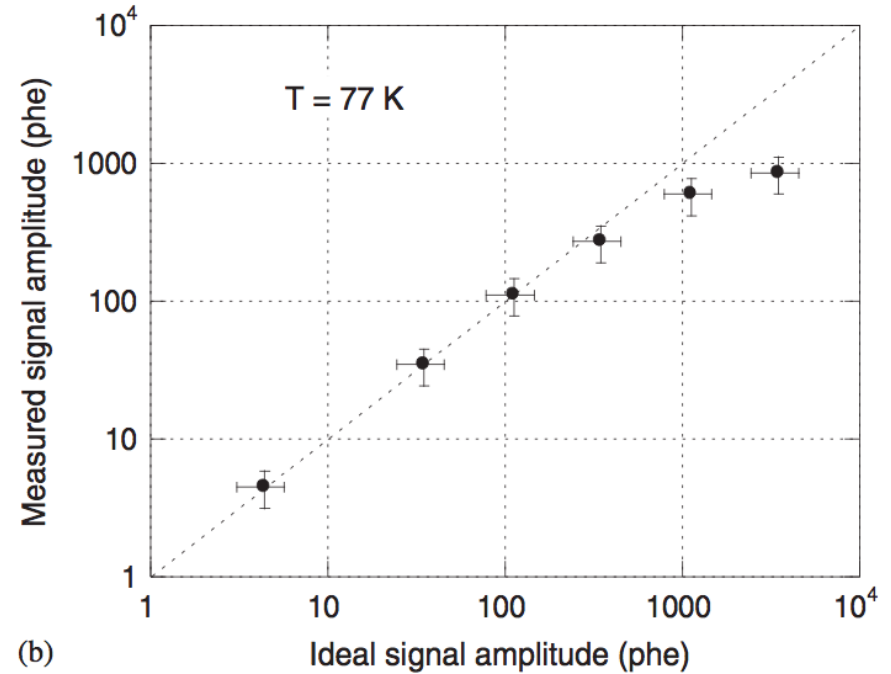
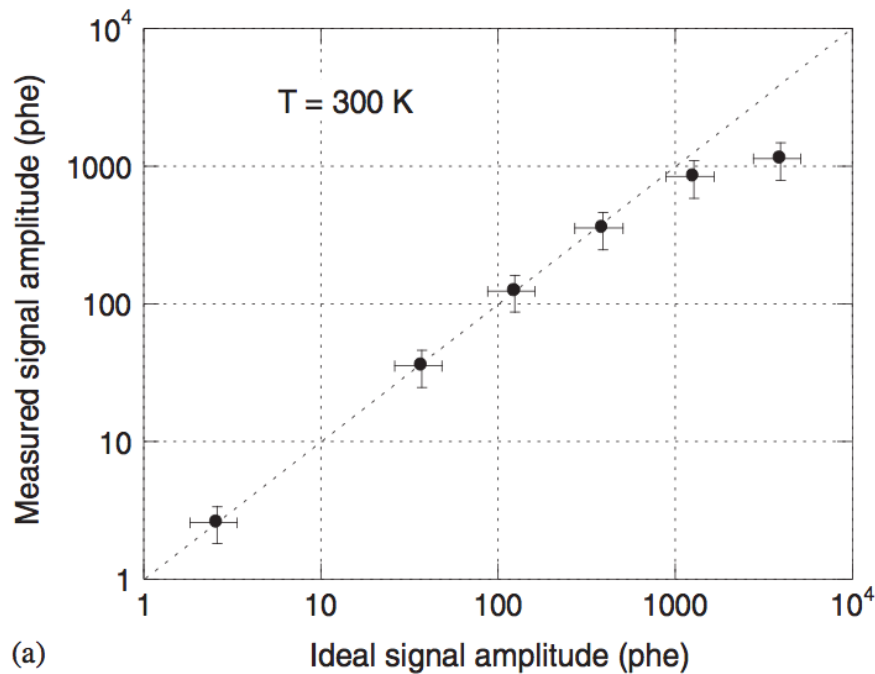

✓ ICARUS PMTs: linear **up to 500 phe**.

✓ No difference in linearity between room and cryogenic temperature.

# Cryogenic temperature: Linearity

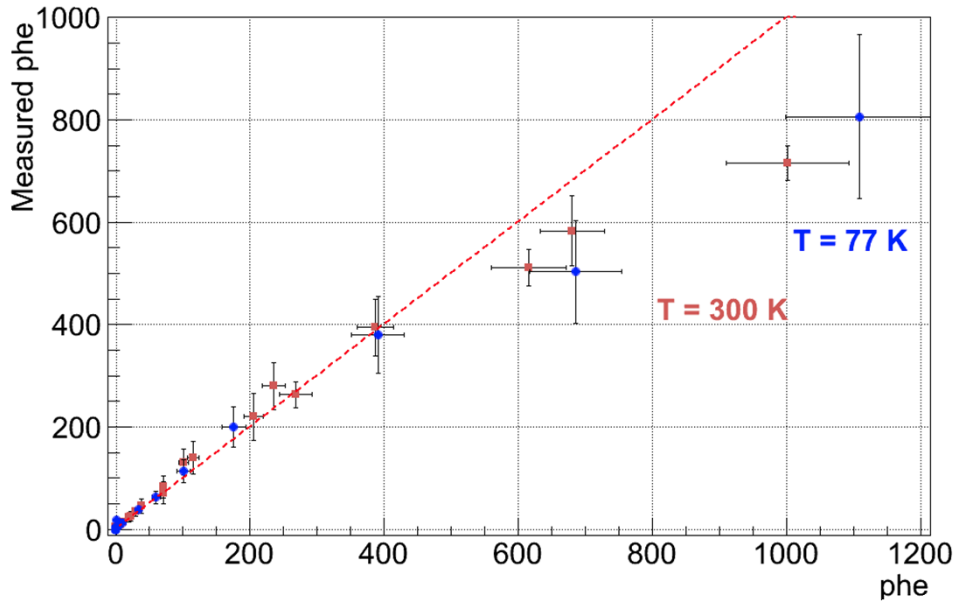

R5912

Linear up to 400 phe

R5912 - 02

Saturation above 10 phe

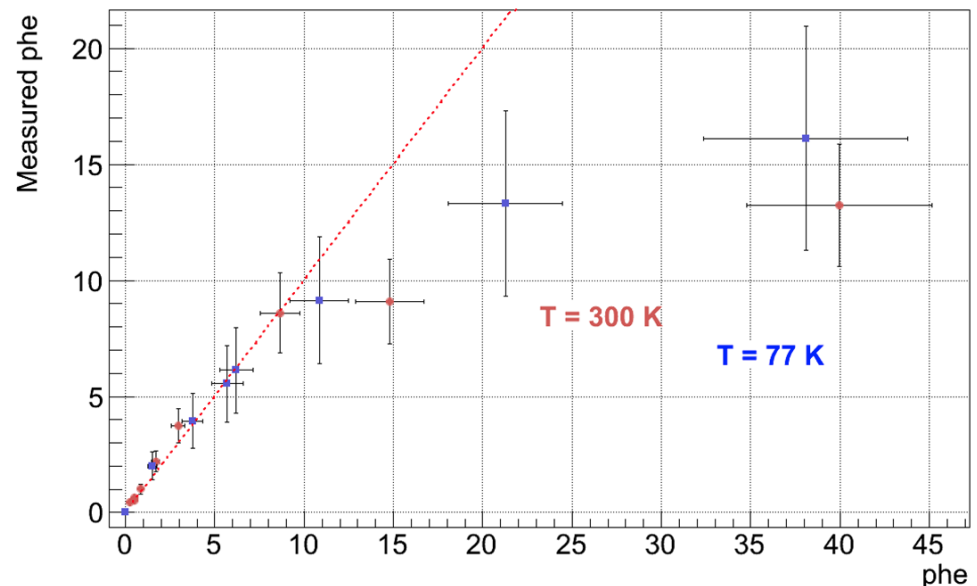

## ETL 9357 FLA

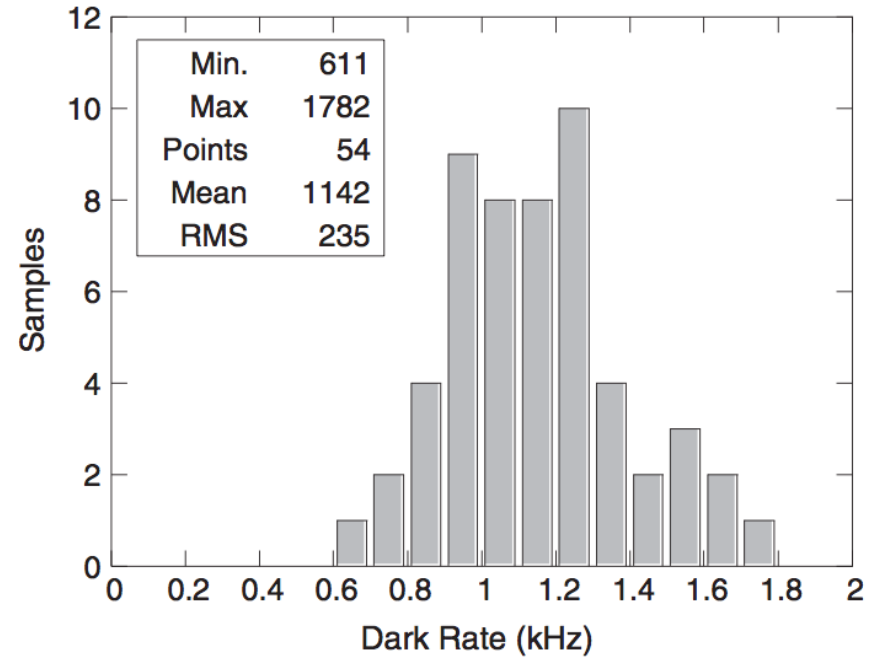
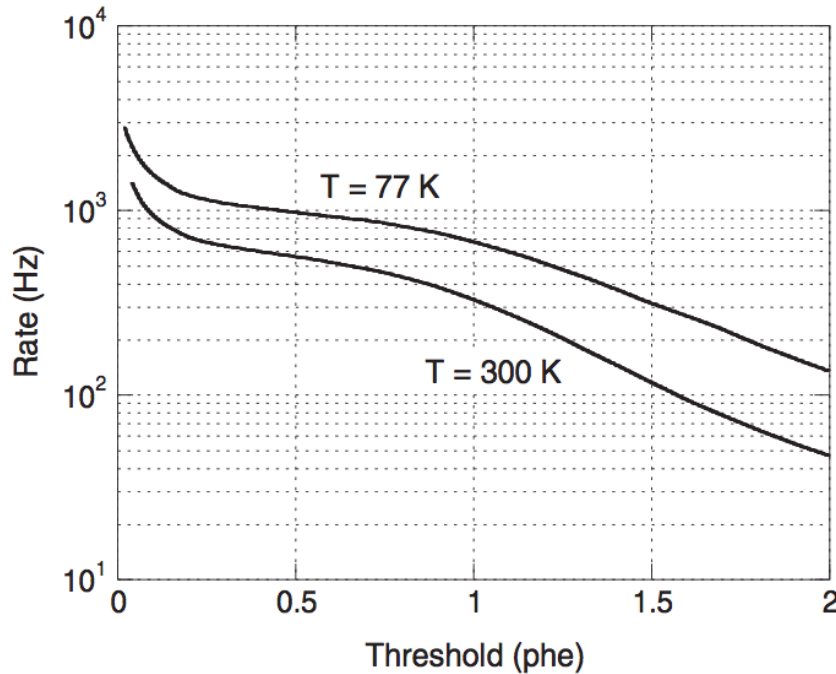

- ✓ ICARUS PMTs: dark rate lies **between 0.6 and 1.8 kHz** for the entire sample.
- ✓ Dark counts **increase** with lowering temperature, due to a **decrease of lattice energy** of cathode material. This implies the rise of the electron escaping probability.

R5912

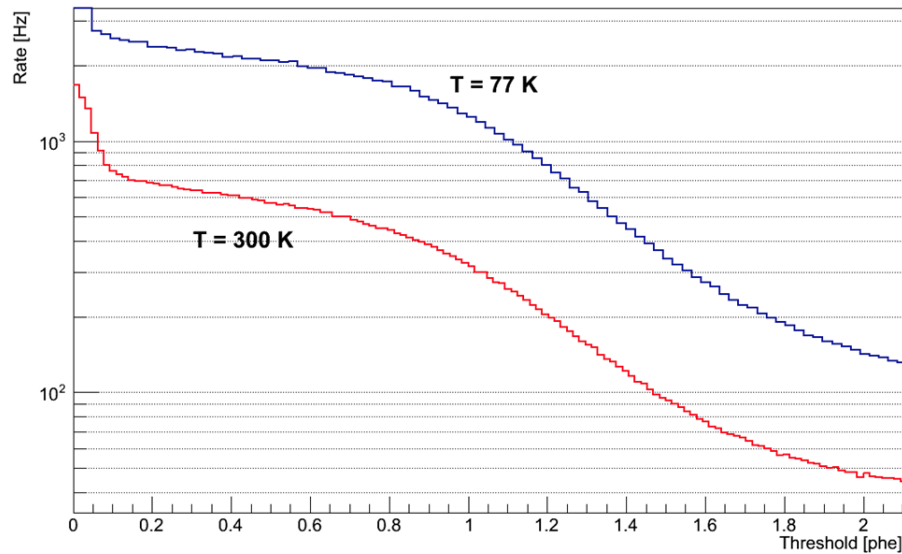

R5912 - 02

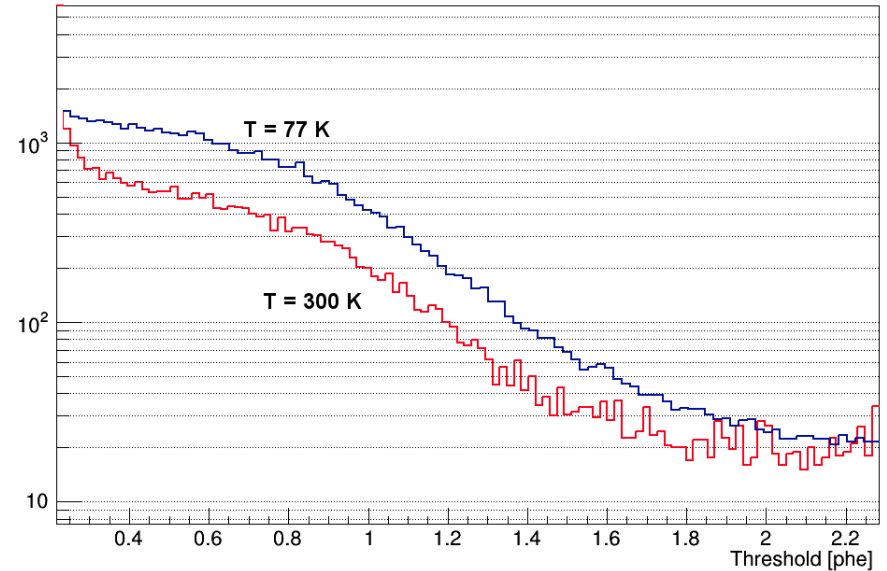

- ✓ 300 K : dark rate  $> 1$  kHz only for very low threshold ( $< 0.1$  phe).
- ✓ Dark counts **increase** with lowering temperature, by a factor **3.5** and **2** for the R5912 and the R5912-02 respectively.

- ✓ We have investigated the behaviour of three different large area PMTs, Hamamatsu R5912 and R5912-02 and ET 9354 KB, to be used in liquefied noble gas detectors.
- ✓ Data were collected both at room and cryogenic temperature, and a comparison was made with the ETL 9357 FLA, successfully employed in ICARUS T600 detector.
- ✓ All tested PMTs show a good photocathode uniformity, except for one case (ET 9354 KB), possibly due to manufacturing defects.
- ✓ In relation to the magnetic field, a huge variation of the gain as a function of PMTs direction is recorded. On the other end, no difference can be seen in the electron transit time.
- ✓ Some problematic behaviour occurred while testing ET 9354 KB. We decided not to make tests on it at cryogenic temperature, before clarifications with the manufacturer.



✓ Tested PMTs show a good behaviour at cryogenic temperature, and are suitable for cryogenic application :

- suitability of the bialkali photocathode on Pt under-layer, to work and detect the light both at room and at cryogenic temperature, is verified;
- gain decrease at low temperature is of the order of 35% for the two devices;
- linearity up to 400 photoelectrons can be achieved for the 10 dynodes model;
- saturation occurs after 10 photoelectrons for the 14 dynodes one;
- increase of dark counts rate at cryogenic temperature does not hinder the use of the devices in real experimental condition.

Thank you !

Back up

R5912

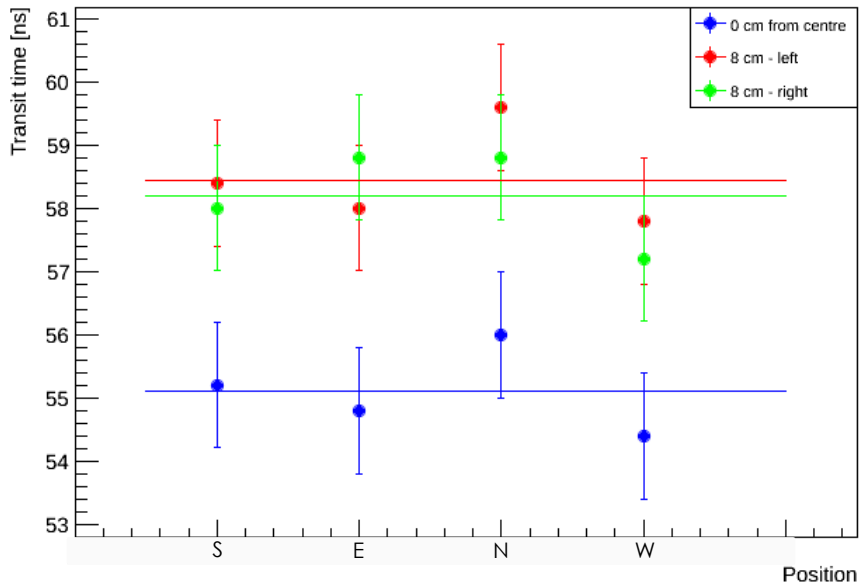

R5912 - 02

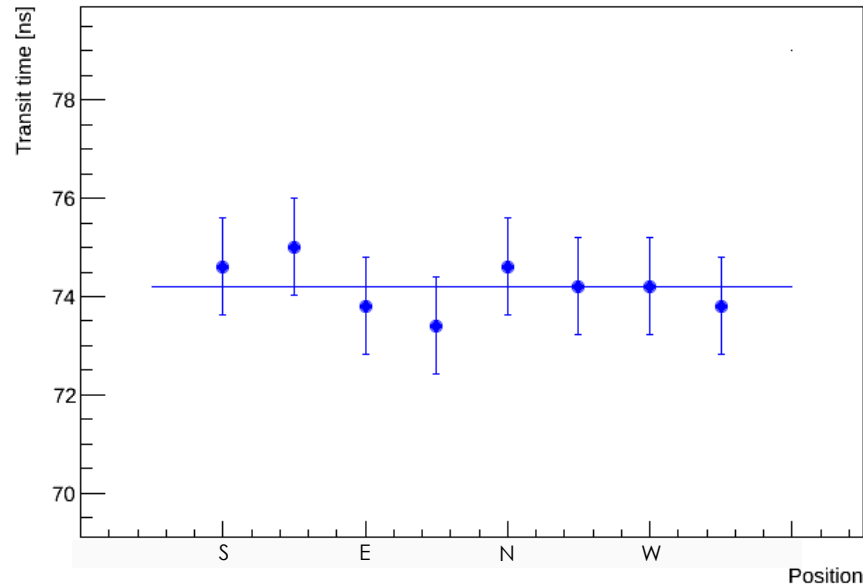

ET 9354KB

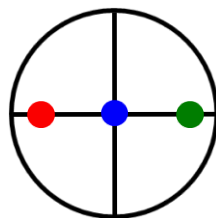
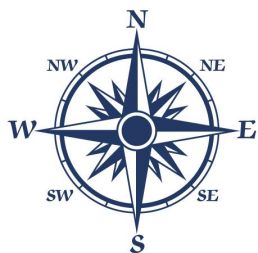
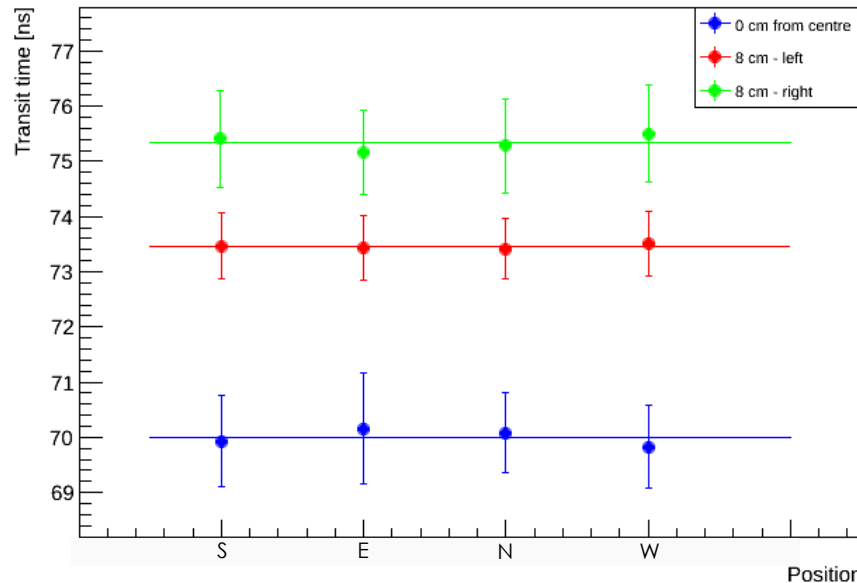

- Transit time seems to be not affected by terrestrial magnetic field. It increases with increasing distance from the PMT window centre.

# Q.E. with TPB coating

- Quantum efficiency is measured, as a function of wavelength, by comparing the current produced on the photo-cathode with that collected with a reference diode, enlightened with the same amount of light.
- All PMTs show a Quantum Efficiency of the order of few percent to VUV incident light, when coated with TPB.

R 5912

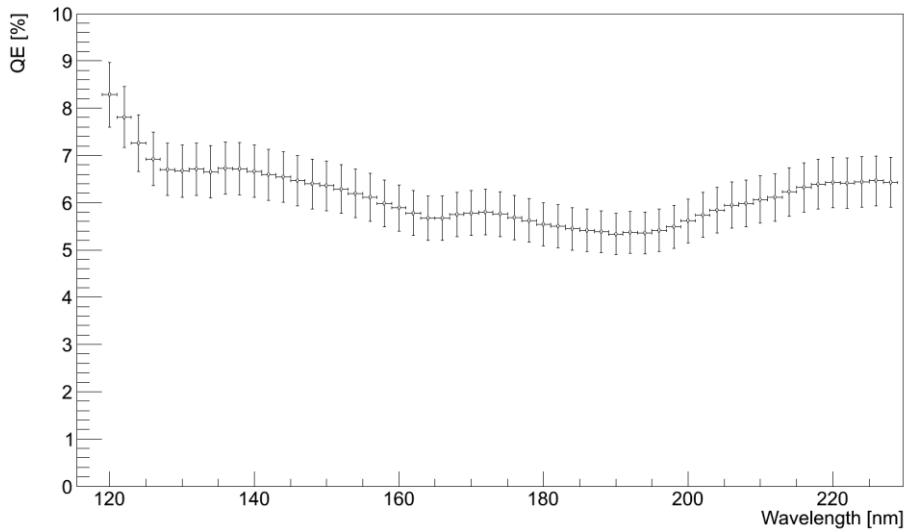

ET 9354 KB

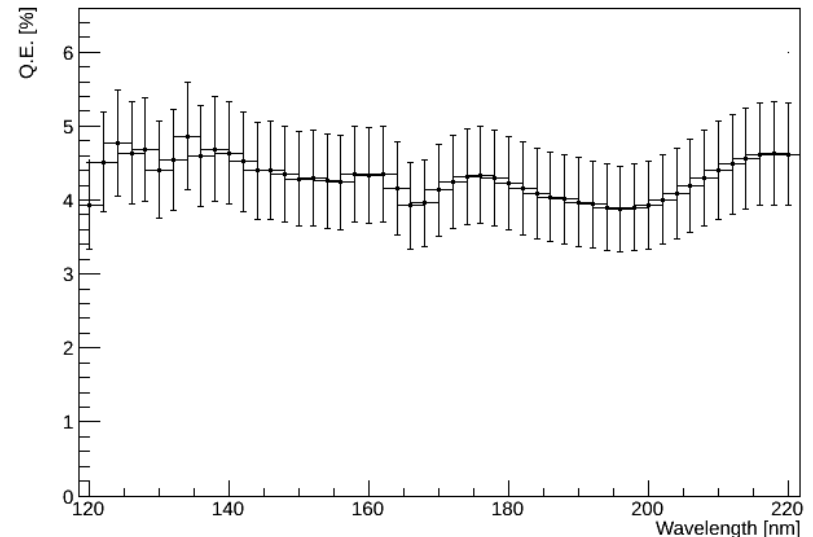

- Comparison is reported between Q.E. of different PMTs, at the wavelength of liquid Argon and liquid Xenon emission peaks.

